

## Absorbed Glass Mat VRLA Industrial Battery Block

Discover® Clean & Green™ Series EV Traction Dry Cell Industrial Batteries provide superior high integrity and reliability for environmentally sensitive areas, commercial, industrial and private applications. The maintenance-free, valve regulated lead acid (VRLA) construction makes Discover® EV Traction Batteries the definitive choice for Mobility and Home Medical Equipment (HME); Broadband and Cable TV (CATV); Uninterruptible Power Supplies (UPS); Telecommunication; Photovoltaic, Solar and Renewable Energy Storage; Electronic and Security; Marine and RV; Golf and Electric Vehicle; Aerial Lifts and Fork Lifts; Floor Machines and Robotics.

### Features & Benefits

### EV Traction Dry Cell

- Completely sealed valve regulated construction.
- Flame arresting pressure regulated safety sealing valves for safety, operating pressure management and protection against atmospheric contamination (excess oxygen being absorbed by negative plates).
- Computer-aided 99.994% pure heavy-duty lead calcium grid designs.
- Tank formed plates guarantees evenly formed and capacity matched plates.
- Discover® proprietary Vision Max® Paste Formula.
- Anchored plate groups to guard against vibration.
- Double insulating Micro porous glass fiber separators.
- Measured and Immobilized electrolyte.
- Vacuum filling and weighing processes.
- Advanced technology for efficient gas recombination of up to 99.9% and freedom from electrolyte maintenance.
- Wide range of operating temperatures (-40°C to 60°C).
- Low self discharge rates (Approx. 1%-3% monthly at 20 °C-25°C / 68°F-77°F).
- High impact reinforced strength copolymer polypropylene cases and flat top designed covers that are rugged and vibration resistant.
- Thermally welded case to cover bonds that eliminate leakage.
- Copper and stainless steel alloy terminals and hardware.
- Multi-terminal options.
- Terminal protectors.
- Removable carry handles.
- Industry leading size and performance options.
- Classified as “NON-SPILLABLE BATTERY” Not restricted for Air (IATA/ICAO) Provision 67, Surface (DOT-CFR-HMR49) or Water (Classified as non-hazardous per IMDG amendment 27) transportation.
- Can be used in multiple orientations (upside down is not recommended).
- Compatible with sensitive electronic equipment.
- Quality Assurance processes with ISO (4400/992579), QS and TUV Certification EMC tested, CE, ETTS Germany (G4M19906-9202-E-16). UL recognized and approved components (MH29050).
- Tellcordia and Bellcore compliant.



Complies with DOT provisions listed in 49CFR173.159 (d). Special provision A67

## Mechanical Characteristics

Industry Type No.	Volts	Standard (optional) Terminals	Dimensions in Inches (mm)				Approx. Weight in Lbs (Kgs)
			L in(mm)	W in(mm)	H in(mm)	TH in(mm)	
24	12	AM	10.7 (272)	6.8 (172)	8.1 (206)	8.9 (226)	56 (26.0)

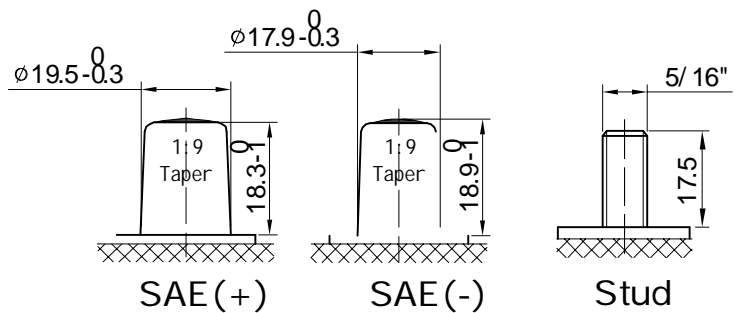
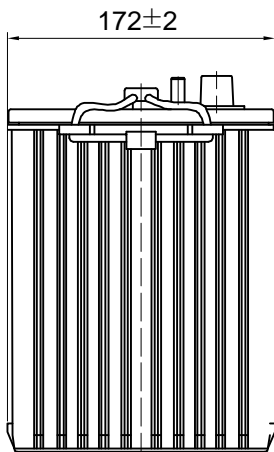
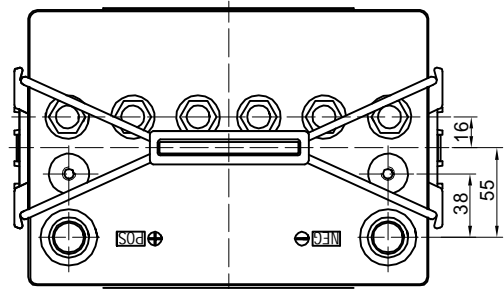
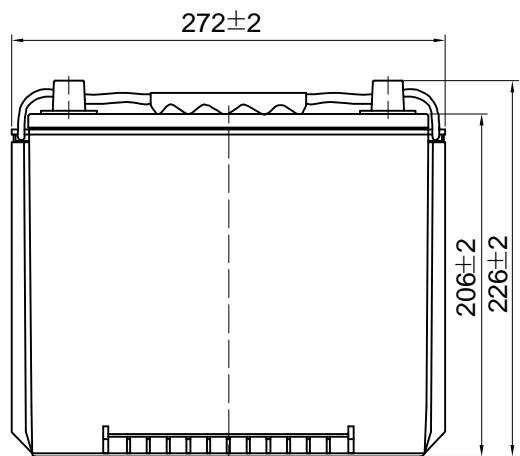

## Electrical Specifications

Ampere Hour Capacity			Minutes of Discharge					R/C	Cranking Amps	
20HR	10HR	5HR	@25A	@56A	@75A	@85A	@100A	@25A	32°F / 0°C	0°F / -18°C
* - Performance averages after 25 cycles										
84	78	74	161	57	38	32	24	150	665	475

Constant current discharge ratings-amperes at 20°C (68°F)

End Point Volts/Cell	5min	10min	15min	30min	45min	1h	3h	5h	10h
1.60V	217	154	125	85.1	64.6	52.0	23.1	15.8	8.18
1.65V	199	145	118	81.8	62.1	50.2	22.6	15.5	8.06
1.70V	181	135	112	78.4	59.6	48.3	22.1	15.2	7.93
1.75V	163	125	105	75.0	57.1	46.4	21.5	14.8	7.80
1.80V	145	115	97.3	71.1	54.5	44.6	20.9	14.4	7.68

Constant power discharge ratings-watts per cell at 20°C (68°F)

End Point Volts/Cell	5min	10min	15min	30min	45min	1h	2h	3h	5h
1.60V	375	276	223	148	112	93.1	59.5	44.7	29.9
1.65V	358	265	215	143	109	90.4	57.9	43.5	29.4
1.70V	340	254	207	138	106	87.7	56.2	42.3	28.8
1.75V	322	242	198	133	103	85.0	54.6	41.1	28.2
1.80V	305	230	189	127	99	82.1	52.9	39.8	27.6

Internal resistance	Fully charged at 20°C: 4.8 mOhms		
Self discharge	<3% of capacity per month at 20°C		
Operating temperature range	Discharge	Charge	Storage
	-20~60°C	-10~50°C	-20~60°C
Short circuit current (20°C)	2500 A		

CHARGE METHODS: Constant voltage charge at 20°C (68°F)	Charge voltage	Temperature compensation	Maximum Current	Peak 5 seconds	Peak 10 seconds	Maximum continuous	Recommended maximum continuous
Standby use	13.6-13.8V	-20mV/°C	Maximum charge current	1C10A	0.75C10A	0.5C10A	0.3C10A
Cyclic use	14.4-14.7V	-30mV/°C	Maximum discharge current	2C10A	1.5C10A	1C10A	0.5C10A

Contact Discover Engineering for OEM specific charging algorithms!

## Charge / Discharge Tables & Graphs

